

# FGH 65

THE EXPANSION JOINT COVER FOR AREAS WITH STRICT HYGIENIC REQUIREMENTS AND HIGH AESTHETIC DEMANDS

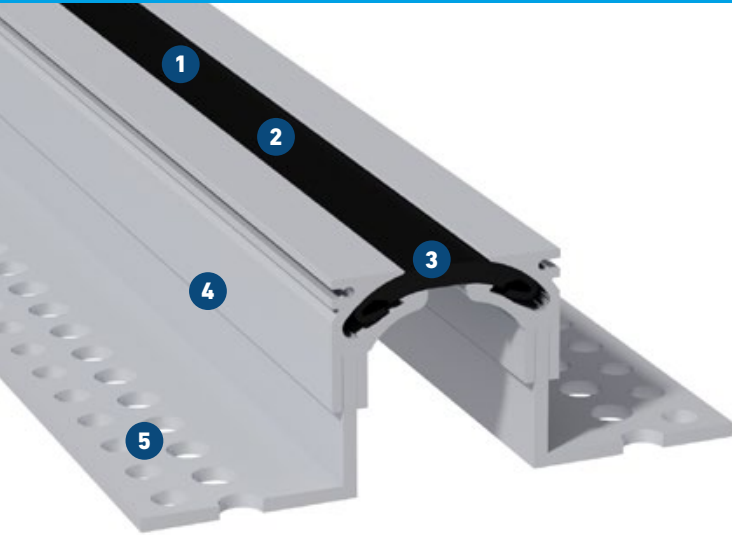

# MIGUTEC

JOINT COVERS FOR EXPANSION JOINTS



- 1 Ultra-smooth insert for residue-free cleaning**  
Thus optimal sterility and physiologically safe
- 2 Seamless, symmetrical visible surface**  
Hard-wear special insert for smoother, low-noise transit
- 3 Innovative solution**  
Suitable for hospital-typical vehicles, such as hospital beds and food trolleys
- 4 High load capacity due to sturdy construction**  
Solid aluminium brackets
- 5 Secure fixing due to MultiHole mounting bracket**  
Flexible anchoring and excellent bond

**Ideal for use with various types of floor covering**

Expansion joint cover	Joint width	Total movement	Visible width	Total width	Joint height	Load bearing capacity*  [kN]	Load bearing capacity*  [kN]
	$b_f \text{ max}$ [mm]	$\Delta b_f$ [mm]	$b_s$ [mm]	$b_t$ [mm]	$h$ [mm]		
FGH 65/38	50	20 ( $\pm 10$ )	65	148	38	30	300
FGH 65/50	50	20 ( $\pm 10$ )	65	171	50	30	300
FGH 65/60	50	20 ( $\pm 10$ )	65	171	60	30	300
FGH 65/70	50	20 ( $\pm 10$ )	65	171	70	30	300

\* no continuous use

All information on load bearing capacity does only apply to non-floating floors.

For installation in asphalt, please ask for our technical advice.

Larger installation heights on request.

**Production length:** 3 m

**Standard colours:** black, grey

**Wall connections:** E3, E4

